

INLINE® SFP MODUL LWL

mit LC Buchsen, 1,25Gb/s



32335M

32335O, 32335N

Ein Small Form-Factor Pluggable (SFP) Gigabit 1000BASE-LX-Transceiver, der eine Vollduplex-Gigabit-Lösung für Distanzen von bis zu 20 Kilometern mit 1,25Gbit/s Übertragungsrate bietet. Passend für Artikel 32324P InLine® PoE+ Gigabit Netzwerk Switch 24 Port.

- Duplex LC-Port
- Multimode 850nm oder Singlemode 1310nm (SFP)
- 1,25Gbit/s

Technische Daten	
Anzahl Ports:	1
Artikel Breite:	1,4 cm
Artikel Höhe:	1,2 cm
Artikel Länge:	6 cm
Max. Distanz:	bis zu 20 km
Typ:	SFP Modul
Variante:	Multi-Mode
Verpackungsart:	InLine® Tüte 20106A
Übertragungsgeschwindigkeit:	1,25 Gb/s

Art. Nr.	Variante	Distanz	EAN
32335O	Single-Mode	10 km	4043718290406
32335N	Single-Mode	20 km	4043718277858
32335M	Multi-Mode	550 m	4043718277841

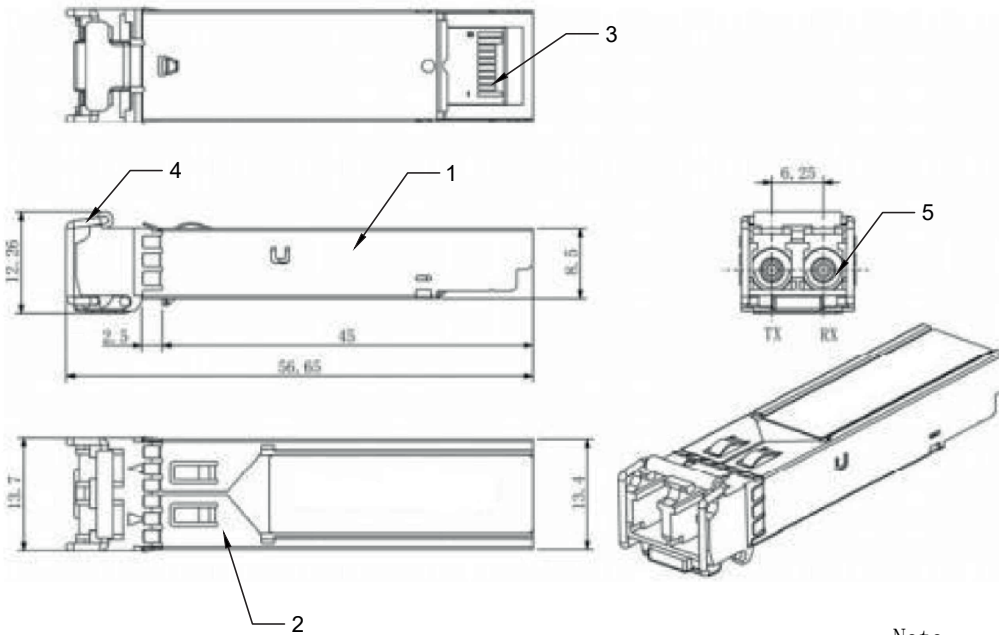

Pin assignment:

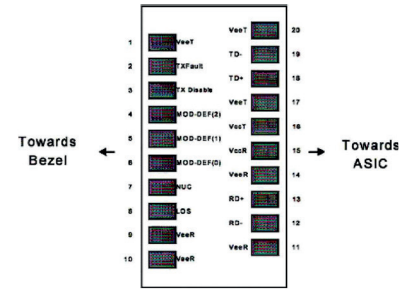

⑤	LC Duplex Connector
④	SFP Ring Metal
③	PCB FR4
②	Stainless steel unlock / shield
①	SFP shell nickel plating of zinc alloy

Note:

- Compliant with SFP MSA and SFF-8472
- Up to 1.25Gb/s Data Links
- Hot-Pluggable
- With DDM function
- Duplex LC connector
- Up to 550m on 50/125µm MMF
- 850nm VCSEL laser transmitter and PIN photo-detector
- Single +3.3V Power Supply
- Maximum Power <1W
- Operating temperature range: 0° C ~70° C
- Class I laser safety requirements.
- RoHS compliant and Lead Free
- CE EMC

● Absolute Maximum Ratings

Parameter	Symbol	Min.	Typical	Max.	Unit
Storage Temperature	T _s	-40		+85	°C
Supply Voltage	V _{cc}	-0.5		4	V
Relative Humidity	RH	0		85	%

● Recommended Operating Environment:

Parameter	Symbol	Min.	Typical	Max.	Unit
Case operating Temperature	T _c	0		+70	°C
Supply Voltage	V _{cc}	3.135		3.465	V
Supply Current	I _{cc}			300	mA
Inrush Current	I _{surge}			I _{cc} +30	mA
Maximum Power	P _{max}			1	W

● Electrical Characteristics (V_{CC}=3.135 to 3.465 Volts)

Parameter	Symbol	Min.	Typical	Max.	Unit	Note
Transmitter Section:						
Input differential impedance	R _{in}	90	100	110		
Single ended data input swing	V _{inpp}	250		1200	mVp-p	
Transmit Disable Voltage	V _D	V _{cc} - 1.3		V _{cc}	V	2
Transmit Enable Voltage	V _{EN}	V _{ee}		V _{ee} +0.8	V	
Transmit Disable Assert Time	T _{assert}			10	us	
Receiver Section:						
Single ended data output swing	V _{out,pp}	250		800	mv	3
LOS Fault	V _{losfault}	V _{cc} - 0.5		V _{cc,host}	V	5
LOS Normal	V _{losnorm}	V _{ee}		V _{ee} +0.5	V	5
Power Supply Rejection	PSR	100			mVpp	6

● Optical Parameters (T_{OP}=-40 to 85°C, V_{CC}=3.135 to 3.465 Volts)

Parameter	Symbol	Min.	Typical	Max.	Unit	Note
Transmitter Section:						
Center Wavelength	λ _c	840	850	860	nm	
Spectral Width(RMS)	λ _{RMS}			0.85	nm	
Optical Output Power	P _{out}	-9		-3	dBm	1
Extinction Ratio	ER	8.2			dB	
Optical Rise/Fall Time	t _r / t _f			260	ps	2
Relative Intensity Noise	RIN			-120	dB/Hz	
Output Eye Mask	Compliant with IEEE802.3z (class 1 laser safety)					
Receiver Section:						
Optical Input Wavelength	λ _i	770		860	nm	
Receiver Overload	P _{ot}	0			dBm	4
RX Sensitivity	Sen			-18	dBm	4
RX_LOS Assert	LOS _A	-29			dBm	
RX_LOS De-assert	LOS _D			-19	dBm	
RX_LOS Hysteresis	LOS _H	0.5			dB	
General Specifications:						
Data Rate	BR		1.25		Gb/s	
Bit Error Rate	BER			10 ⁻¹²		
Max. Supported Link Length on 50/125µm MMF@1.25Gb/s	L _{max}		550		m	
Total System Budget	LB	8			dB	

Note:

1. The optical power is launched into MMF.
2. 20-80%.
3. Jitter measurements taken using Agilent OMNIBERT 71.8 in accordance with GR-253.
4. Measured with PRBS 2³¹ at 10⁻¹² BER

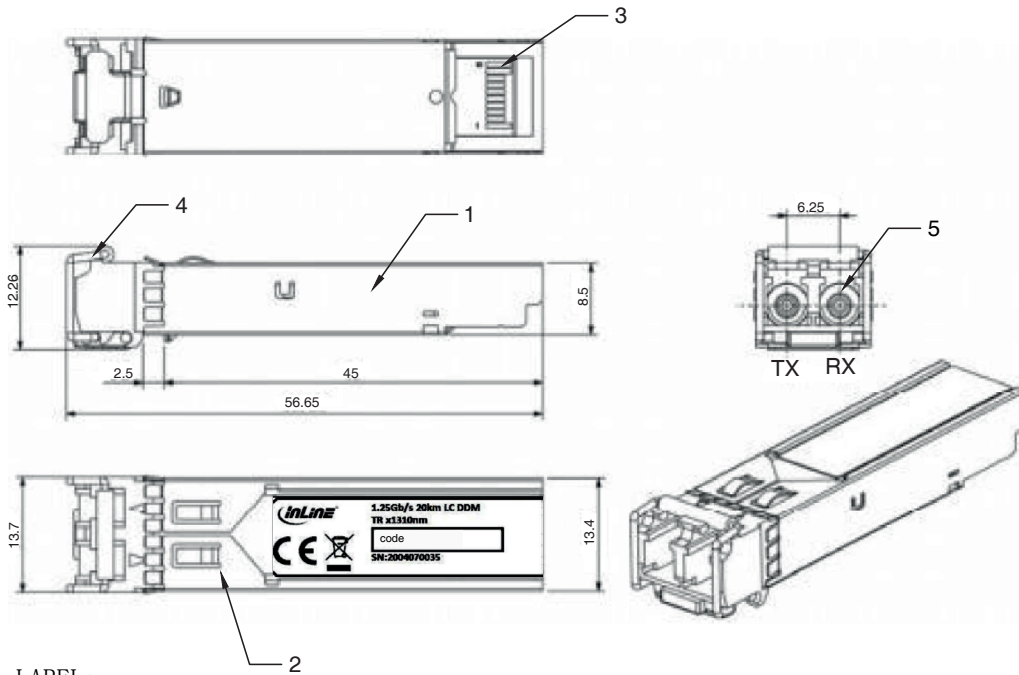

Pin assignment:

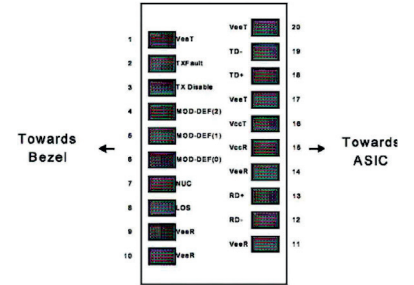

LABEL :

⑤	LC Duplex Connector
④	SFP Ring Blue
③	PCB FR4
②	Stainless steel unlock / shield
①	SFP shell nickel plating of zinc alloy

Note:

- Compliant with SFP MSA and SFF-8472
- Up to 1.25Gb/s Data Links
- Hot-Pluggable
- With DDM function
- Duplex LC connector
- Up to 20km on 9/125 μm SMF
- 1310nm FP and PIN photo-detector
- Single +3.3V Power Supply
- Maximum Power <1W
- Operating temperature range: 0° C ~70° C
- Class I laser safety requirements.
- RoHS compliant and Lead Free
- CE EMC

● Absolute Maximum Ratings

Parameter	Sym bol	M in.	Typical	M ax.	Unit
Storage Temperature	T _s	-40		+85	°C
Supply Voltage	V _{cc}	-0.5		4	V
Relative Humidity	RH	0		85	%

● Recommended Operating Environment

Parameter	Sym bol	M in.	Typical	M ax.	Unit
Case operating Temperature	T _c	0		+70	°C
Supply Voltage	V _{cc}	3.135		3.465	V
Supply Current	I _{cc}			300	mA
Inrush Current	I _{surge}			I _{cc} +30	mA
Maximum Power	P _{max}			1	W

● Electrical Characteristics (VCC = 3.135 to 3.465 Volts)

Parameter	Sym bol	M in.	Typical	M ax.	Unit	Note
Transmitter Section:						
Input differential impedance	R _{in}	90	100	110		
Single ended data input swing	V _{inpp}	250		1200	mVp-p	
Transmit Disable Voltage	V _d	V _{cc} - 1.3		V _{cc}	V	2
Transmit Enable Voltage	V _{EN}	V _{ee}		V _{ee} +0.8	V	
Transmit Disable Assert Time	T _{dassert}			10	us	
Receiver Section:						
Single ended data output swing	V _{outpp}	250		800	mv	3
LOS Fault	V _{losfault}	V _{cc} - 0.5		V _{cc} _host	V	5
LOS Normal	V _{losnom}	V _{ee}		V _{ee} +0.5	V	5
Power Supply Rejection	PSR	100			mVpp	6

● Optical Parameters (VCC = 3.135 to 3.465 Volts)

Parameter	Sym bol	M in.	Typical	M ax.	Unit	Note
Transmitter Section:						
Center Wavelength	λ _c	1270	1310	1360	nm	
Spectral Width(RMS)	λ _{RMS}			3	nm	
Optical Output Power	P _{out}	-9		-3	dBm	1
Extinction Ratio	ER	8.2			dB	
Optical Rise/Fall Time	t _r / t _f			260	ps	2
Relative Intensity Noise	RIN			-120	dB/Hz	
Output Eye Mask	Compliant with IEEE802.3z (class 1 laser safety)					
Receiver Section:						
Optical Input Wavelength	λ _d	1260		1360	nm	
Receiver Overload	P _{dl}	0			dBm	4
RX Sensitivity	Sen			-24	dBm	4
RX_LOS Assert	LOS _A	-29			dBm	
RX_LOS De-assert	LOS _D			-19	dBm	
RX_LOS Hysteresis	LOS _H	0.5			dB	
General Specifications:						
Data Rate	BR		1.25		Gb/s	
Bit Error Rate	BER			10 ⁻¹²		
Max. Supported Link Length on 9/125 μm SMF@1.25Gb/s	L _{max}		20		km	
Total System Budget	LB	8			dB	

Note

1. The optical power is launched into SMF.
2. 20-80%
3. Jitter measurements taken using Agilent OMNIBERT 718 in accordance with GR-253.
4. Measured with PRBS 2⁷⁻¹ at 10⁻¹² BER

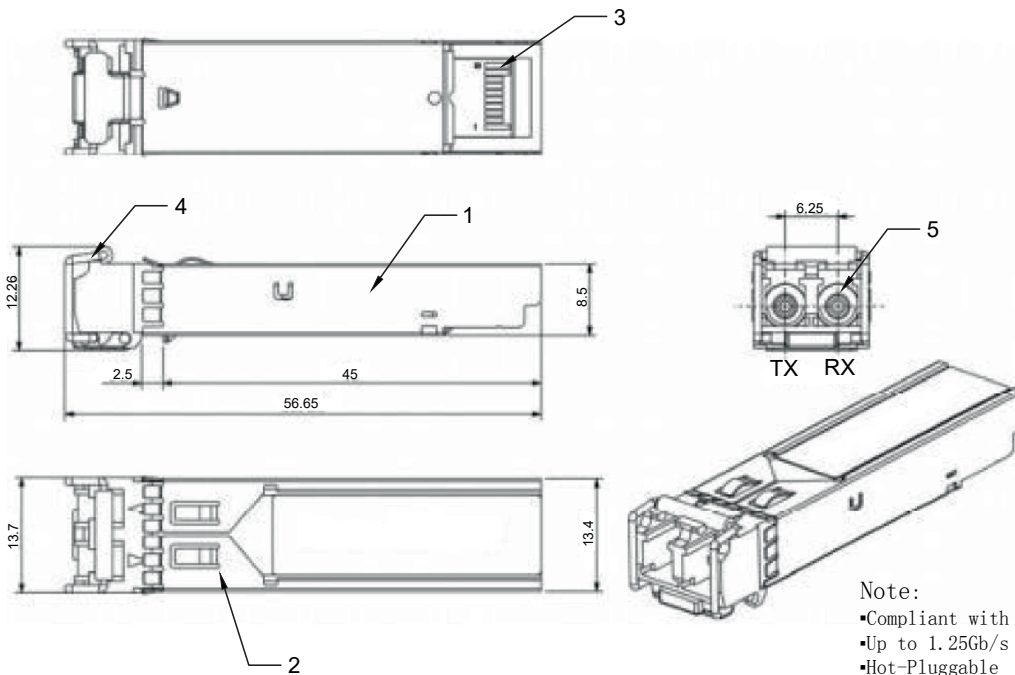

Pin assignment:

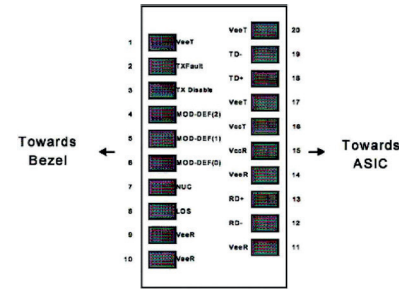

⑤	LC Duplex Connector
④	SFP Ring Blue
③	PCB FR4
②	Stainless steel unlock / shield
①	SFP shell nickel plating of zinc alloy

Note:

- Compliant with SFP MSA and SFF-8472
- Up to 1.25Gb/s Data Links
- Hot-Pluggable
- With DDM function
- Duplex LC connector
- Up to 10km on 9/125µm SMF
- 1310nm FP and PIN photo-detector
- Single +3.3V Power Supply
- Maximum Power <1W
- Operating temperature range: 0° C ~70° C
- Class I laser safety requirements.
- RoHS compliant and Lead Free
- CE EMC

● Absolute Maximum Ratings

Parameter	Symbol	Min.	Typical	Max.	Unit
Storage Temperature	T _s	-40		+85	°C
Supply Voltage	V _{cc}	-0.5		4	V
Relative Humidity	RH	0		85	%

● Recommended Operating Environment:

Parameter	Symbol	Min.	Typical	Max.	Unit
Case operating Temperature	T _c	0		+70	°C
Supply Voltage	V _{cc}	3.135		3.465	V
Supply Current	I _{cc}			300	mA
Inrush Current	I _{surge}			I _{cc} +30	mA
Maximum Power	P _{max}			1	W

● Electrical Characteristics (V_{CC}=3.135 to 3.465 Volts)

Parameter	Symbol	Min.	Typical	Max.	Unit	Note
Transmitter Section:						
Input differential impedance	R _{in}	90	100	110		
Single ended data input swing	V _{inPP}	250		1200	mVp-p	
Transmit Disable Voltage	V _D	V _{cc} - 1.3		V _{cc}	V	2
Transmit Enable Voltage	V _{EN}	V _{ee}		V _{ee} +0.8	V	
Transmit Disable Assert Time	T _{assert}			10	us	
Receiver Section:						
Single ended data output swing	V _{out,pp}	250		800	mv	3
LOS Fault	V _{losfault}	V _{cc} - 0.5		V _{cc} -0.5	V	5
LOS Normal	V _{losnorm}	V _{ee}		V _{ee} +0.5	V	5
Power Supply Rejection	PSR	100			mVpp	6

● Optical Parameters (V_{CC}=3.135 to 3.465 Volts)

Parameter	Symbol	Min.	Typical	Max.	Unit	Note
Transmitter Section:						
Center Wavelength	λ _c	1270	1310	1360	nm	
Spectral Width(RMS)	λ _{RMS}			3	nm	
Optical Output Power	P _{out}	-9		-3	dBm	1
Extinction Ratio	ER	8.2			dB	
Optical Rise/Fall Time	t _r / t _f			260	ps	2
Relative Intensity Noise	RIN			-120	dB/Hz	
Output Eye Mask	Compliant with IEEE802.3 z (class 1 laser safety)					
Receiver Section:						
Optical Input Wavelength	λ _{in}	1260		1360	nm	
Receiver Overload	P _{in}	0			dBm	4
RX Sensitivity	S _{en}			-24	dBm	4
RX_LOS Assert	LOS _A	-29			dBm	
RX_LOS De-assert	LOS _D			-19	dBm	
RX_LOS Hysteresis	LOS _H	0.5			dB	
General Specifications:						
Data Rate	BR		1.25		Gb/s	
Bit Error Rate	BER			10 ⁻¹²		
Max. Supported Link Length on 9/125µm SMF@1.25Gb/s	L _{max}		20		km	
Total System Budget	LB	8			dB	

Note

1. The optical power is launched into SMF.
2. 20-80%.
3. Jitter measurements taken using Agilent OMNIBERT 718 in accordance with GR-253.
4. Measured with PRBS 2³¹ at 10⁻¹² BER

Bei weiteren Fragen wenden Sie sich bitte an marketing@inline-info.com

www.inline-info.com

Disclaimer

InLine® ist eine Marke der INTOS ELECTRONIC AG | Siemensstraße 11 | D-35394 Gießen

Dokumentation © 2025 INTOS ELECTRONIC AG

Alle Rechte vorbehalten. Ohne schriftliche Zustimmung des Herausgebers darf dieses Dokument auch nicht auszugsweise in irgendeiner Form reproduziert werden oder unter Verwendung elektrischer, mechanischer oder chemischer Verfahren vervielfältigt oder verarbeitet werden.

Es ist möglich, dass das vorliegende Dokument noch drucktechnische Mängel oder Druckfehler aufweist. Die Angaben in diesem Dokument werden jedoch regelmäßig überprüft und Korrekturen in der nächsten Ausgabe vorgenommen. Für Fehler technischer oder drucktechnischer Art und ihre Folgen übernehmen wir keine Haftung. Alle Warenzeichen und Schutzrechte werden anerkannt. Änderungen im Sinne des technischen Fortschritts können ohne Vorankündigung vorgenommen werden. Unsere Produkte, einschließlich der Verpackung, sind kein Spielzeug, sie könnten kleine Teile und scharfe Objekte enthalten. Bitte von Kindern fernhalten.